

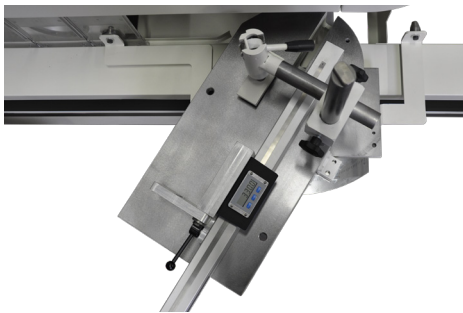

ADVANCED TENONER

The Compact High Performance Pack is applicable to the Pentho Compact 3 or 4 depending of the customers application. With spindle(s) of 300 mm and 7 or 9 individual cnc-positionings this tenoner can make the switch between different programs in a time of 15 sec. All axes will position simultaneously. The easy and straight forward graphical application allows the operator to make any type of single tenon wright from the first time.



The table can be swivelled 60° in two directions. The working area of the table does not change.

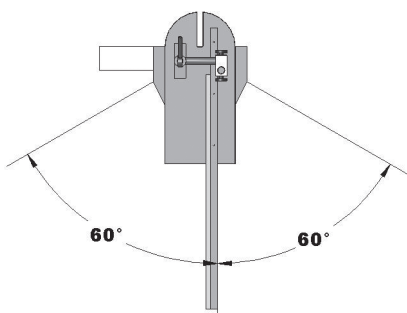

7" touch panel for the operation of the machine and starting of all motors

The safety-screen covers the complete machine. Loading and unloading still remains easy.



All spindles are horizontally and vertically adjustable with 0,1 mm accuracy.

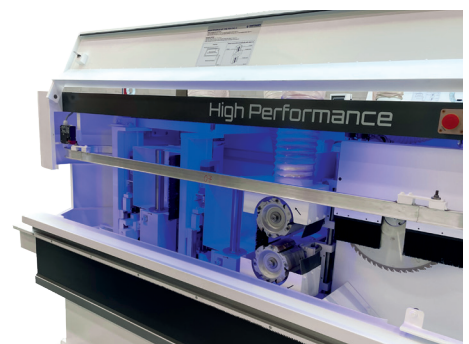



TECHNICAL DESCRIPTION

GENERAL

7" touch panel :	For the operation of the machine Starting of all motors by the panel
Security :	Conform CE
Dimensions :	2200 (2700) x 1700 x 1600 mm
Total Extraction :	1 x Ø 80 mm ; 3 (4) x Ø 150 mm

TABLE

Table mounting :	vertically attached; extra solid
Movement :	manual table; automatic movement option
Table :	Swiveling: +60° to -60°; fixed in height
Backing wood :	Clamp for straight backing wood Round backing wood option
Clamps :	vertical manual clamp vertical pneumatic clamp(s) option
Length Fence :	2.4 m digital length-fence with 1 backstop 2.4 m automatic length-fence option
Dimensions :	160 mm x 600 mm (usable)

CUT OFF SAW

Adjustment :	horizontal 20 / 150 mm – cut-off capacity 150 mm
Positioning :	CNC-positioned (1 x Horizontal)
Tooling :	noise reduced saw included - Ø 400 mm
Motor :	2,2 kW – 3000 t/min
Dust extraction :	Ø 80 mm

TENON HEADS

Movement :	horizontal upper -16 / +68 mm lower 0 / +68 mm vertical upper +6 / +149 mm lower -0,5 / +80 mm
Positioning :	CNC-positioned (2 x horizontal and 2 x vertical)
Tooling :	tenon heads included
Motor :	2 x 2.2 kW – 4500 t/min
Dust extraction :	2 x Ø 150 mm

VERTICAL SPINDLE(S)

Movement :	horizontal 0 / 118 mm (for Ø 320 mm) vertical -20 / +269 mm
Positioning :	CNC-positioned 1 (2) horizontal and 1 (2) vertical
Spindle :	300 mm – Ø spindle 50 mm / Prolock
Tooling :	Ø max. 350 mm (Ø 320 mm advised)
Motor :	7,5 kW – 4000 t/min
Dust extraction :	Ø 150 mm

OPTIONS

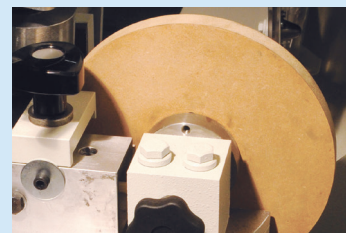

Round backing wood with 6 manual adjustable positions.

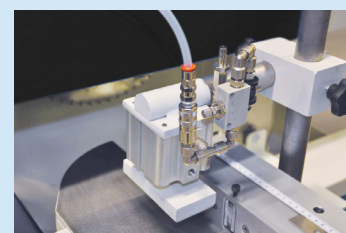

Vertical pneumatic clamp

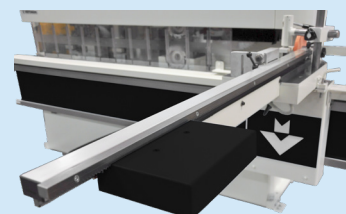

Automatic length-fence



Automatic table movement with adaptive cycle